

MODEL RPM10 / RPM20 (-LON) PRESSURA™ ROOM PRESSURE MONITOR

INSTALLATION INSTRUCTIONS

WARNING

The Model RPM10 and RPM20 (-LON) Room Pressure Monitors must be wired to 24 VAC only. Wiring the unit to 110 VAC will cause serious damage to the unit and void the warranty.

The pressure sensor must be mounted through the wall between the controlled space (isolation room) and referenced space (ante room / hallway).

Go to www.tsi.com to download the Operation & Service Manual for the Model RPM10 or RPM20.

These installation instructions guide the installer through the installation of the TSI Model RPM10 PresSura™ Room Pressure Monitor or the TSI Model RPM20 (-LON) PresSura Room Pressure Monitor. The installation instructions cover all monitor versions. Unless specified otherwise, figures and instructions apply to all three versions. Please read these instructions thoroughly before beginning installation.



This product is classified by Underwriters Laboratories, Inc.® for use in through-penetration firestop systems. See UL fire resistance directory.

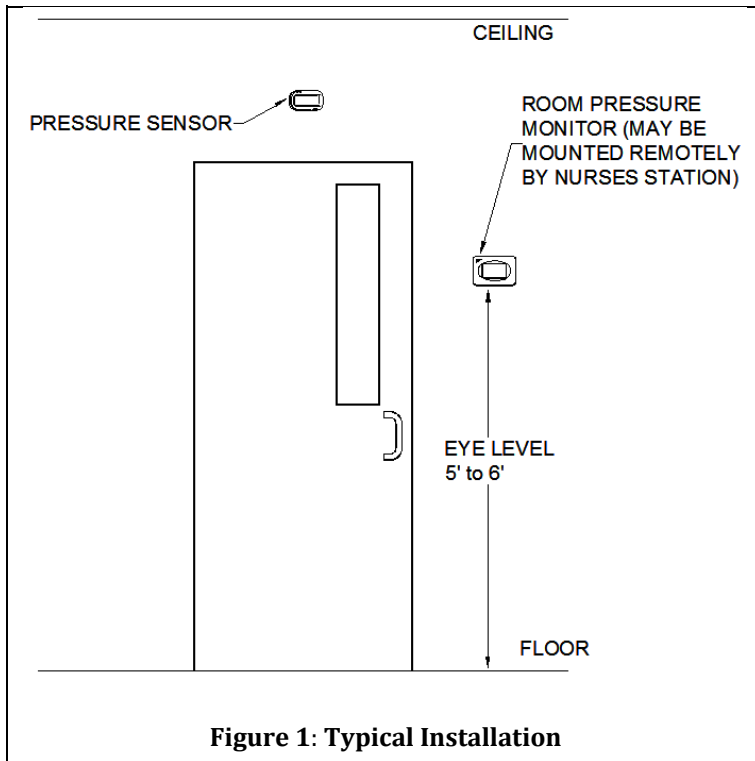

Component List

Part Number	Qty	Description
800243	1	Pressure sensor with cable
	<i>or</i>	
801913	1	Transducer Pick-ups
800980		RPM10 Room Pressure Monitor
	<i>or</i>	
800981/800982	1	RPM20 / RPM20-LON Room Pressure Monitor



Pressure Sensor Installation

WARNING

800243 pressure sensor must be mounted through the wall between the controlled space (isolation room) and referenced space (hallway), exactly as shown in Figure 3 and Figure 4.

- Determine pressure sensor location (Figure 1, Figure 3, and Figure 4). Pressure sensor typically mounts in the reference space, and the dummy housing mounts in the isolation room.
NOTE: Pressure sensor is not symmetrical. If sensor is to be centered over hallway door, measure one inch to the left of center for 2 1/4" hole. Dummy sensor will be 2" off center on other side of wall.
- The pressure sensor must be orientated on the wall as shown in Figure 2. Looking at the mounted sensor, sensor hole is on the left (2 1/4") and wire hole is on the right.
- Drill a 2 1/4" hole through each side of the wall to accept the sensor tube.
- Drill a 7/8" hole on the side of the wall that the pressure sensor will be mounted. This hole is for the six-conductor sensor cable. Refer to Figure 2 for a hole mounting pattern.
- Slide sensor cover to right and remove screw that holds the sensor base to the pressure sensor (Figure 2). Remove pressure sensor and store in a safe place.
- From the side of the wall the sensor will be mounted, slide the sensor tube through the wall. Mark the tube where it is flush with wall. Remove sensor tube and cut tube 1/8 inch shorter than flush marking.
NOTE: If 12" sensor tube needs to be extended, use same size or larger diameter tube. Drill out 1/2" sensor hole in dummy case to match ID of tube extension.
- From the side of the wall the sensor will be mounted, slide the sensor tube through the wall. Slide the dummy base over the end of the tube. Screw the pressure sensor base and dummy base to the wall (Figure 3 and Figure 4).

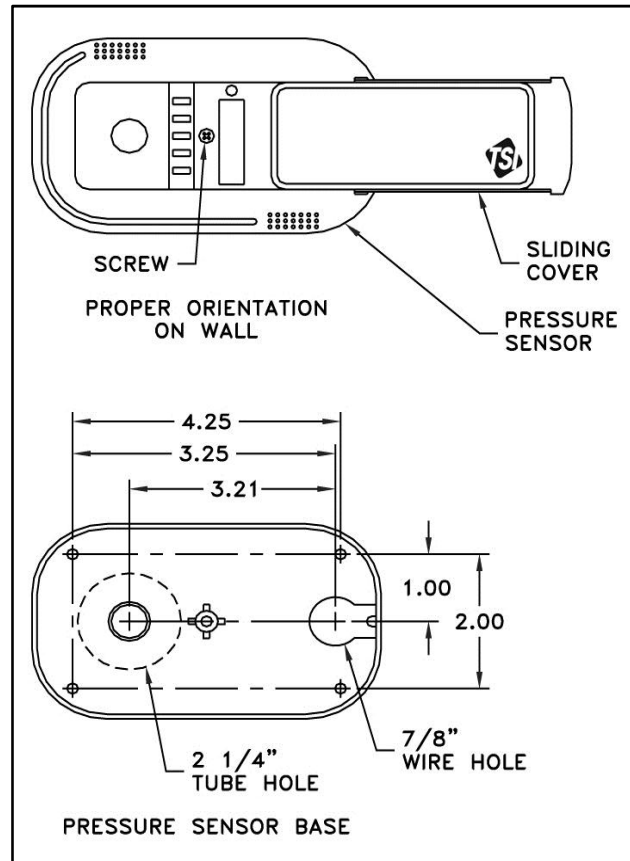

Figure 2: Pressure Sensor Orientation and Mounting Template

- Wire the pressure sensor per Figure 8 to Figure 22. Run sensor cable to the room pressure monitor 6" x 4" electrical rough-in box.
- Insert fire protection sealant (provided) into 7/8" wire hole to seal.
- Install and screw the pressure sensor and dummy cover onto the bases. Slide covers to the left to hide the sensor. Finished installation should look as shown in Figure 4.

WARNING

Do **not** touch the sensor element in the pressure sensor. Do **not** run wires through the air passage. Doing so will damage the sensing element.

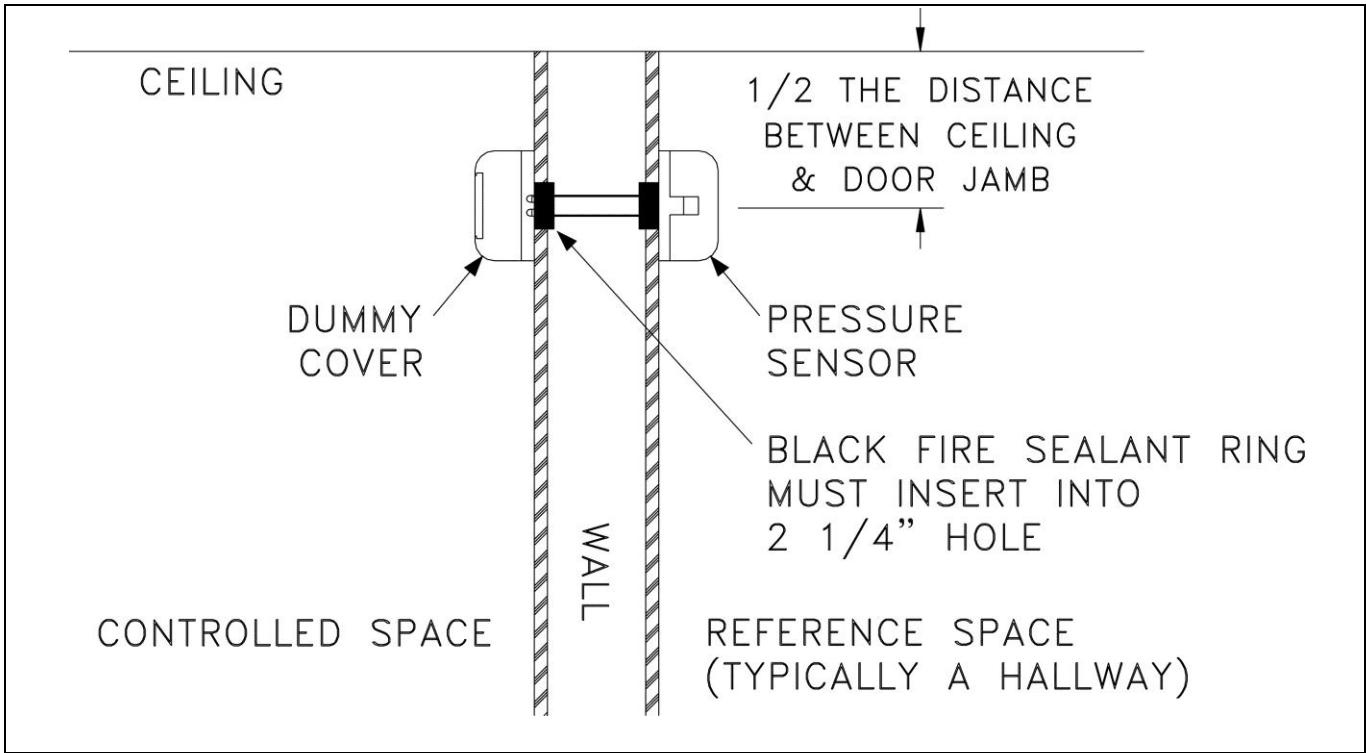

Figure 3: Cutaway View of Mounted Pressure Sensor

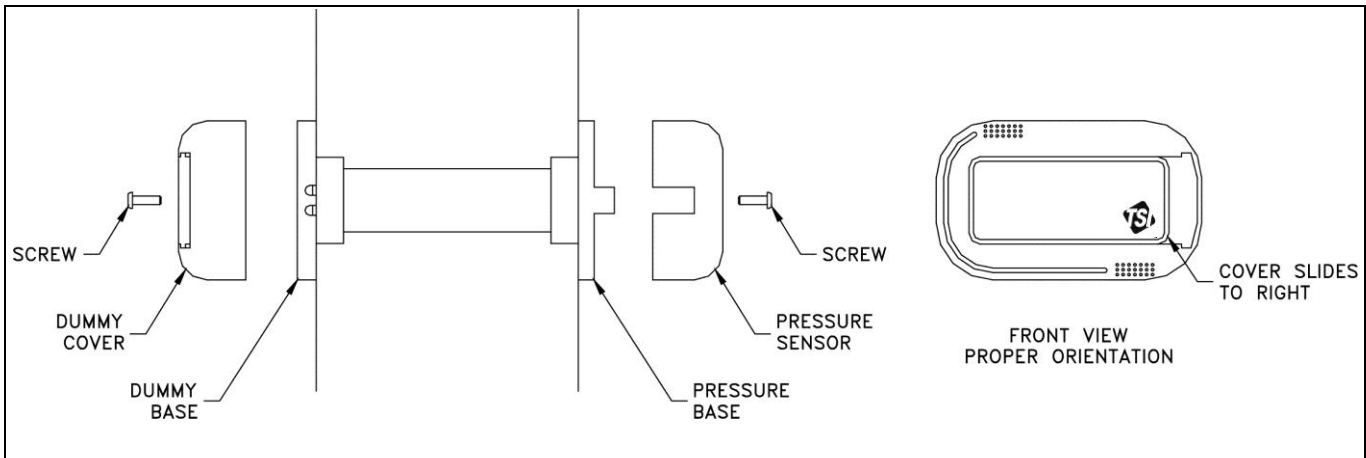

Figure 4: Pressure Sensor Mounting

Pressure Transducer Installation

WARNING

801913 pressure plates must be mounted in the wall between the controlled space (clean room) and referenced space (hallway), exactly as shown in Figure 5 and Figure 6.

- Install pressure transducer in desired location (typically above ceiling). The transducer must be mounted on a wall in the correct position per Figure 5 (screws not provided). Do **not** mount pressure transducer to duct or other vibrating surface.
- Wire the pressure transducer per Figure 9 or Figure 10. Run sensor cable to the Clean Room Pressure Monitor 6" x 4" electrical rough-in box.
- Determine pressure sensor location (Figure 1, Figure 5 and Figure 6). Pressure sensor typically mounts in the reference space, and the plate mounts in the clean room.
- Drill a 2¼-inch hole through each side of the wall to accept the sensor tube.
- Run pneumatic tubing from transducer to sensor locations. For a positively pressurized space, the high port should be connected to the controlled space and the low port to the reference space. Similarly, for a negatively pressurized space, the low port should be connected to the controlled space and the high to the reference space.
- Connect the pneumatic tubing to the nipple on the back side of the pressure plate.
- Insert the pressure plate into the hole in the wall. Screw the pressure plate to the wall. The finished assembly should look like Figure 5.

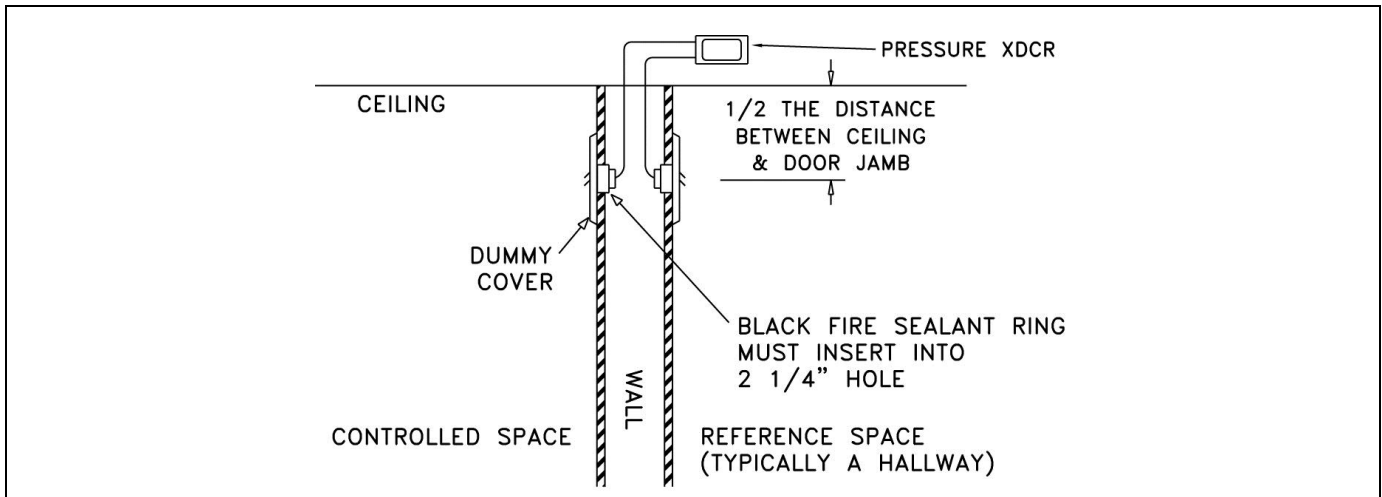

Figure 5: Cutaway View of Mounted Pressure Transducer Assembly

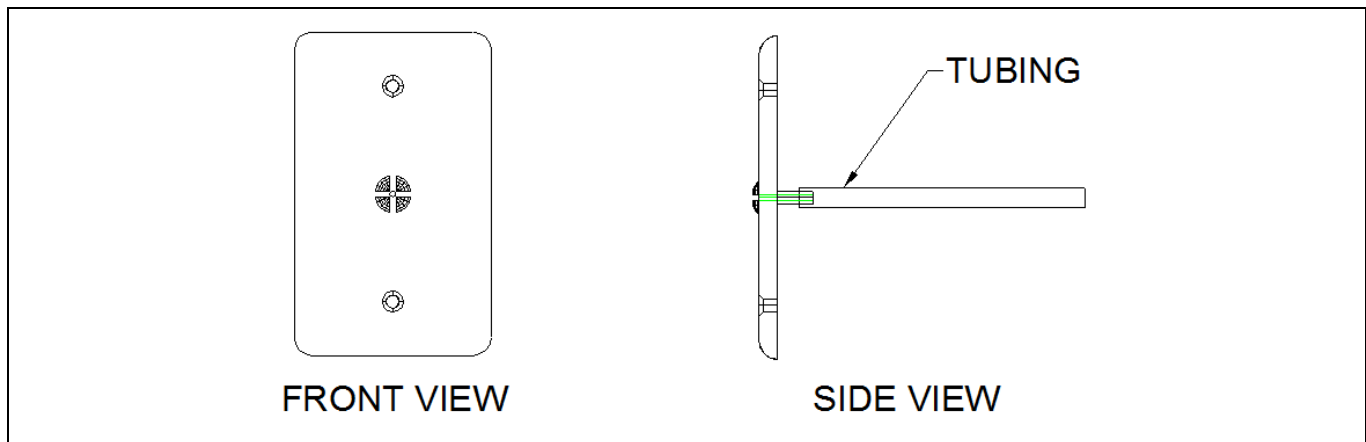

Figure 6: Pressure Transducer Mounting

Pressure Monitor Installation

Pressure Monitor Rough-in

- Select the mounting location of the pressure monitor. The construction plans normally show the mounting location. If no location is specified, then the unit is typically installed as shown in Figure 1. Alternate mounting locations are nurses' station, other staff areas, etc.
- Install a standard triple gang electrical box (6" × 4"). The electrical box must be installed level and flush with the wall surface.
- Screw PresSura DIM to electrical box (Figure 7).

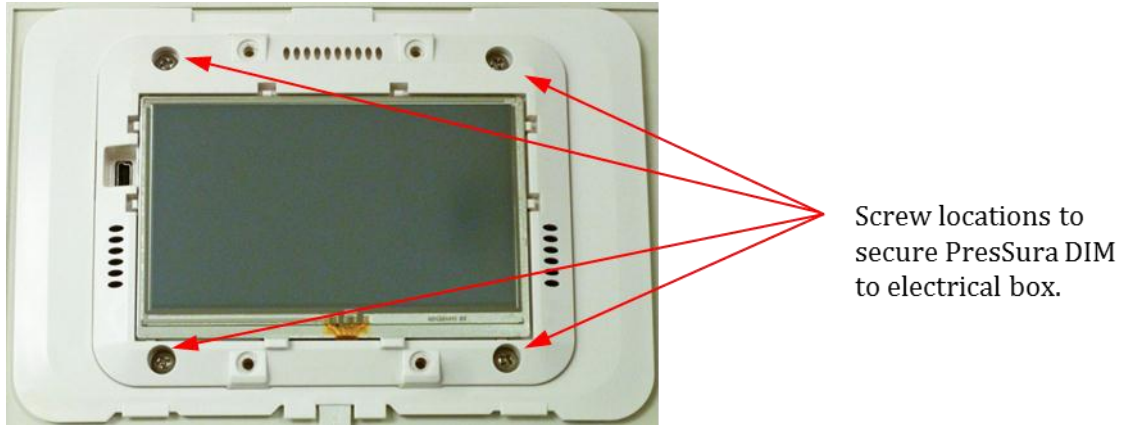

Figure 7: Pressure Monitor Mounting

Pressure Monitor Wiring

WARNING

Do **not** connect more than 24 VAC to any terminal.

Do **not** apply voltage to the RS-485 output, BACnet output, analog output, or control output. Severe damage may occur to the unit if voltage is applied.

Wiring Recommendations

- TSI recommends stranded wire.
- Comply with local and national electrical codes.
- Follow good wiring practices:
 - Do **not** run control wiring in the same conduit or wireway as power wiring.
 - Control cables should cross power cables at a 90-degree angle.
 - Use a consistent color code to maintain polarity.
 - Control signals require "home run" wiring / star configuration. Do **not** daisy-chain control wires or use a series configuration.
 - Use daisy-chain configuration for connecting the nurses' station to monitors and controllers.
- Remove the connectors from the back of the pressure monitor.
- Refer to the wiring diagrams, Figure 8 to Figure 22 for proper wiring installation.
- If additional options need to be wired, refer to building prints for proper wiring diagram.
- Plug the connectors back into the pressure monitor.
- Carefully push the wires into the electrical box and mount the pressure monitor. Install four screws to hold pressure monitor firmly to base. Install cover and slide left to hide display.
- Press cover plate onto PresSura Monitor.

Power Requirements

Digital Interface Module (DIM) Each
24VAC, 50/60 Hz, 3VA

Through the Wall Sensor Each
24VAC, 50/60 Hz, 3VA

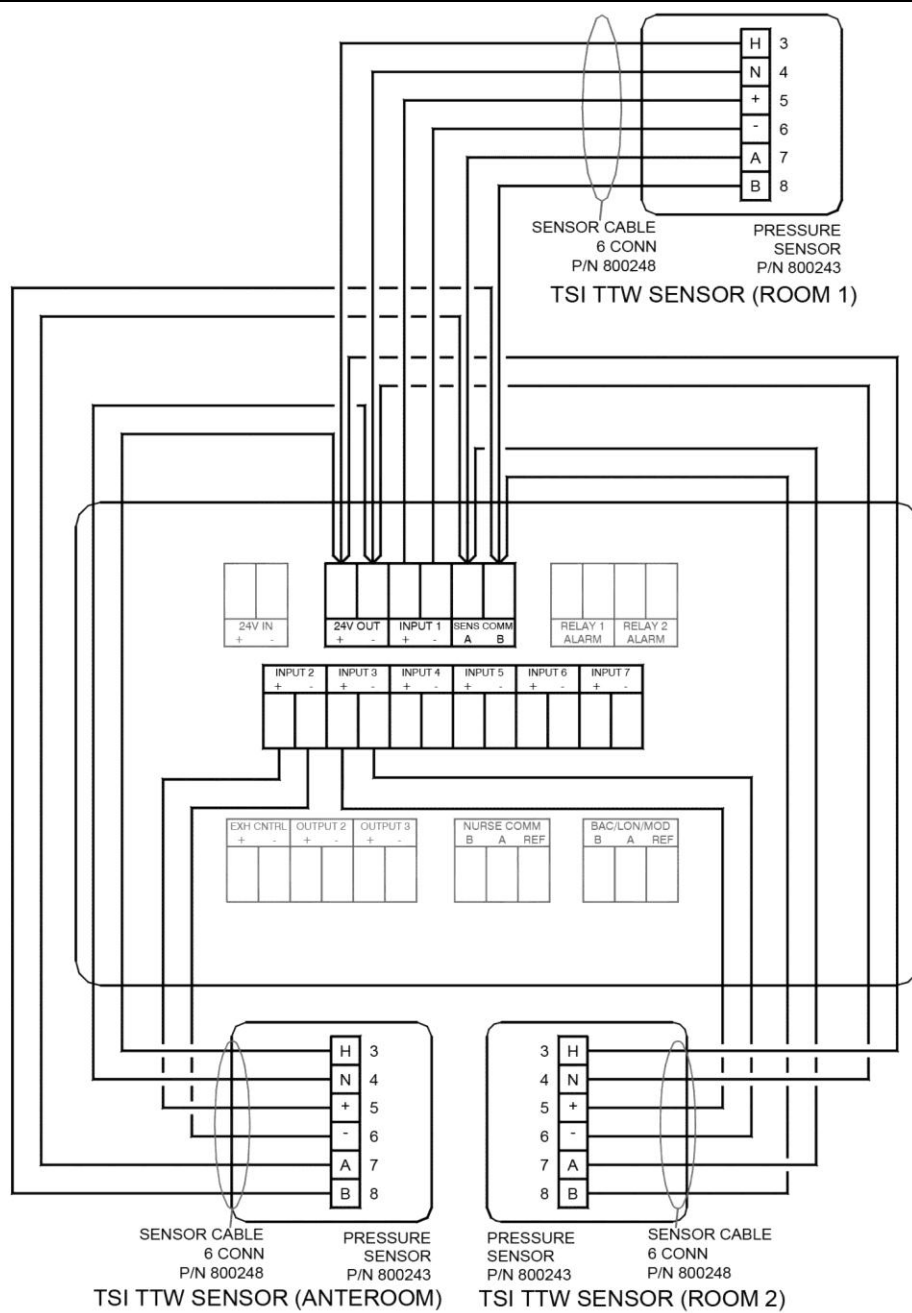

WARNING: Monitor must be wired exactly as wire diagram shows. Making modifications to the wiring may severely damage the unit.

Figure 8: Through-The-Wall Sensors Wiring to Model RPM10 / RPM20



NOTE: Model RPM10 does *not* support Room 2 or Anteroom Through-The-Wall Sensors.
NOTE: Number of sensors will vary per application.

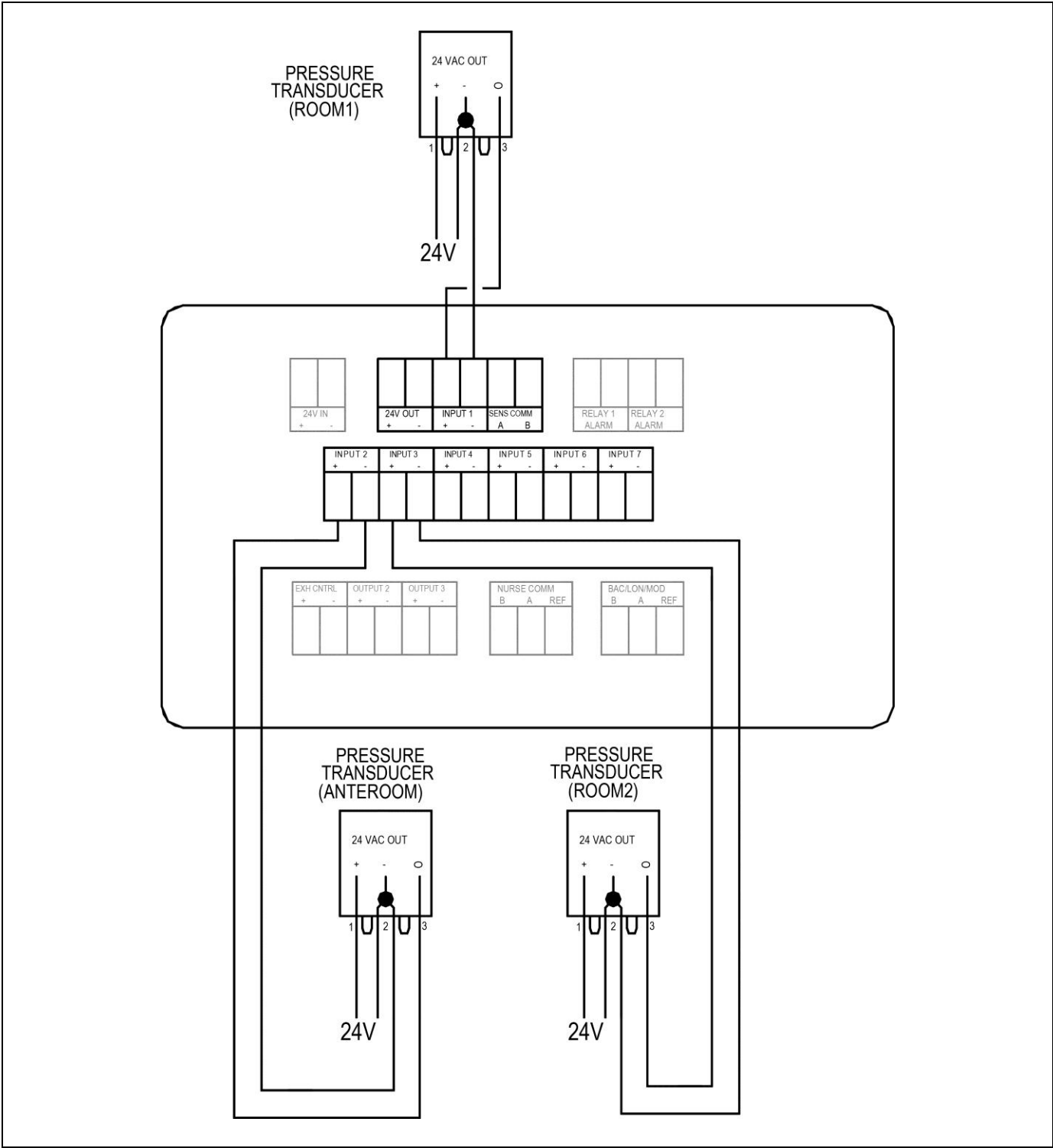

Figure 9. Pressure Transducer Sensors Wiring to Model RPM10 / RPM20



NOTE: Model RPM10 does *not* support Room 2 or Anteroom Pressure Transducer Sensors.
NOTE: Number of sensors will vary per application.

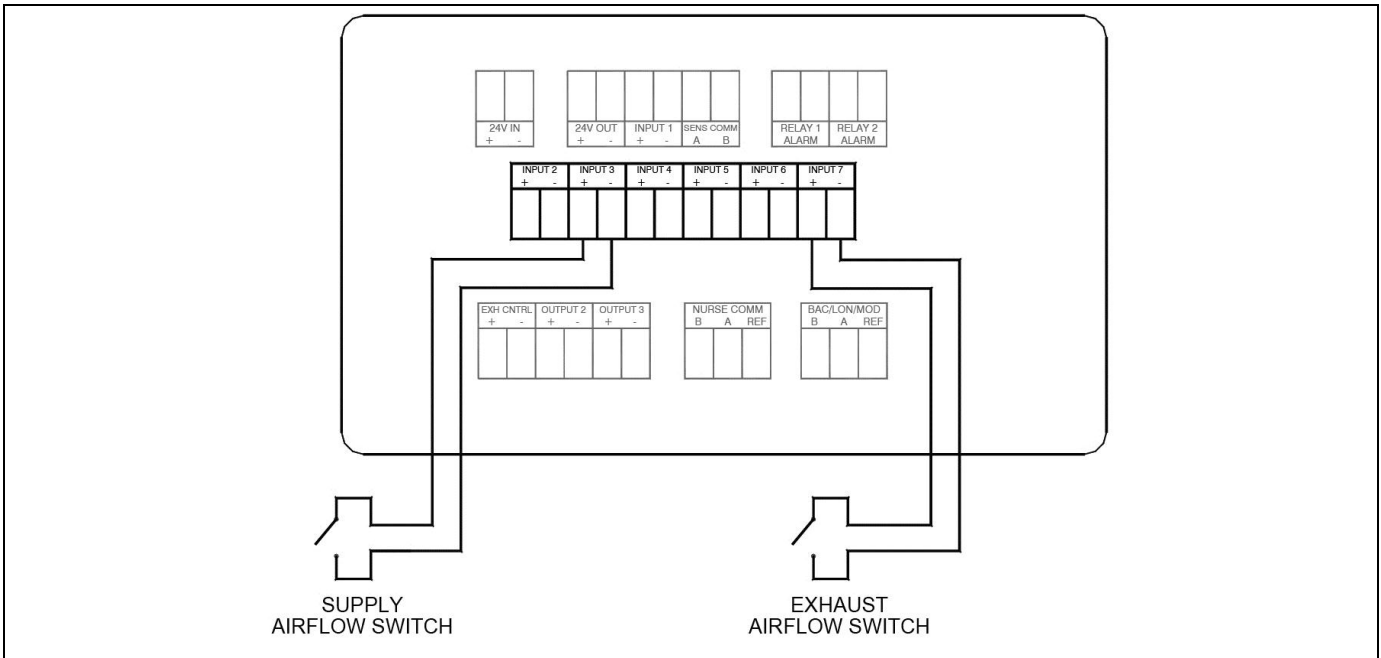

Figure 10. Optional Supply / Exhaust Flow Switch Wiring to Model RPM10 / RPM20

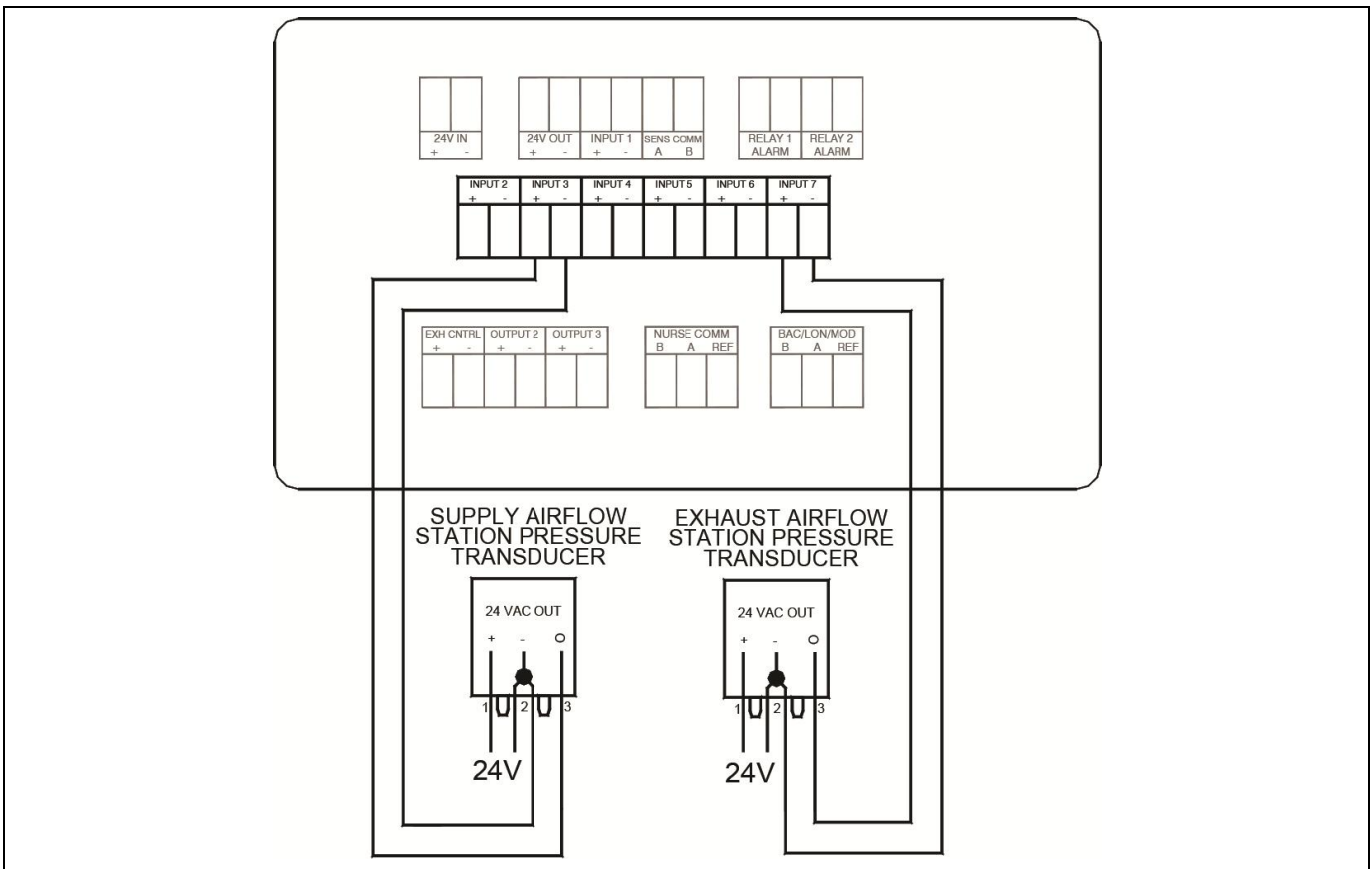

Figure 11. Optional Supply / Exhaust Pressure-Based Flow Station Wiring to Model RPM10 / RPM20

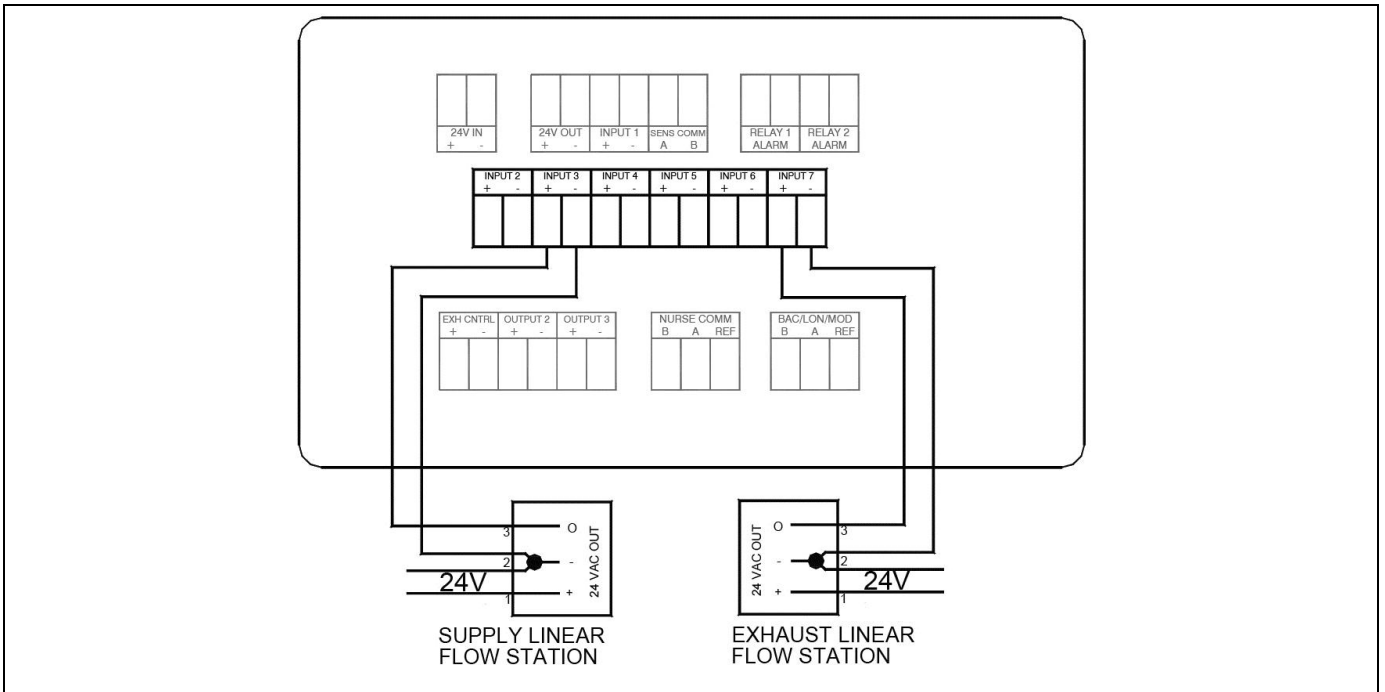

Figure 12. Optional Supply / Exhaust Linear Flow Station Wiring to Model RPM10 / RPM20

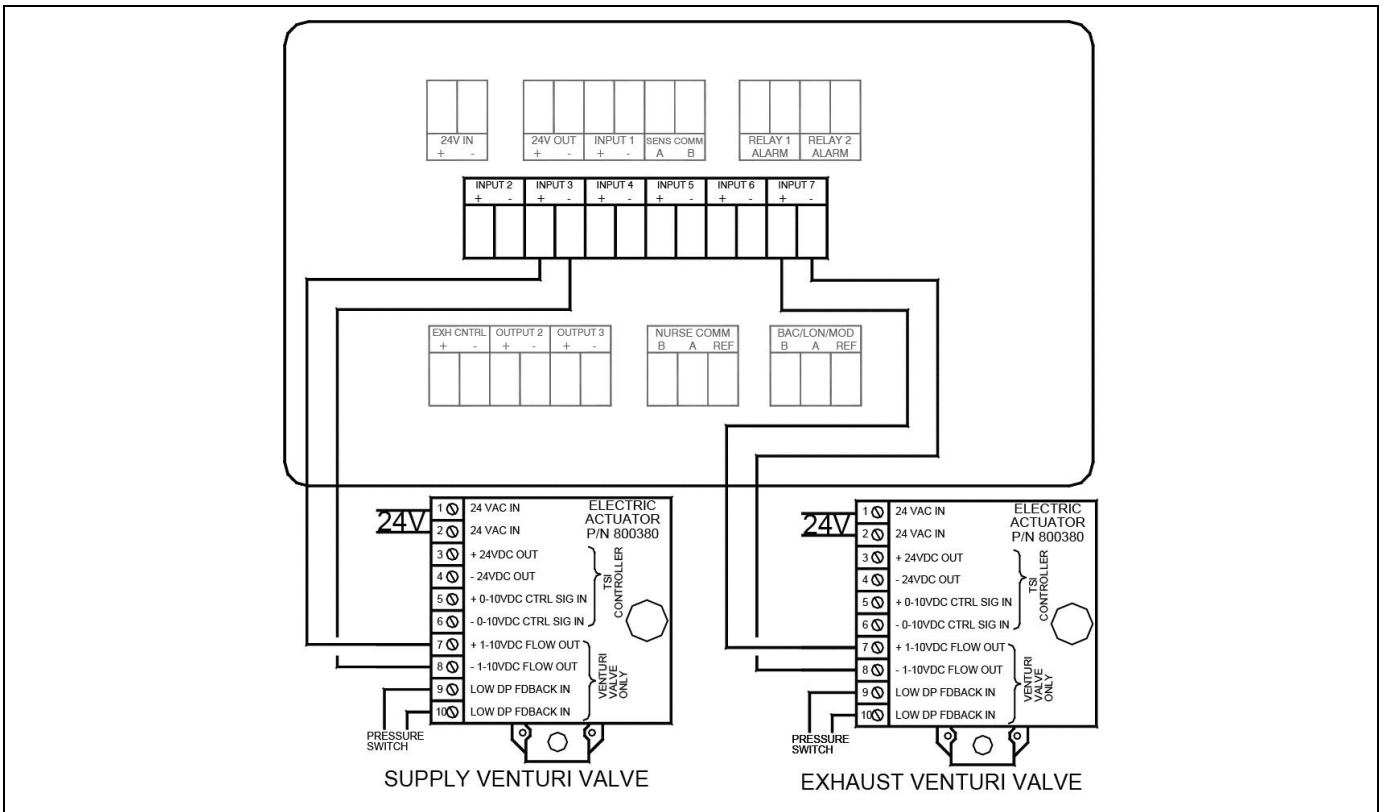

Figure 13. Optional Supply / Exhaust Venturi Valve Wiring to Model RPM10 / RPM20

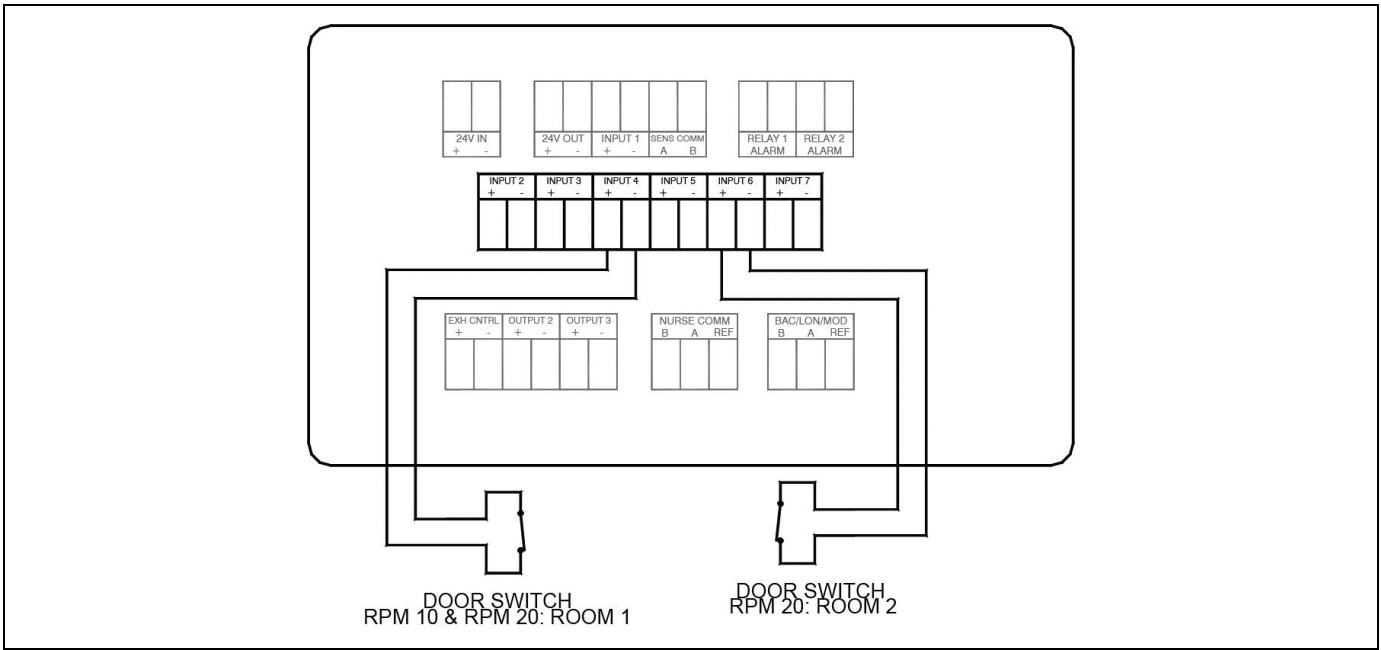

Figure 14. Optional Door Switch Wiring to Model RPM10 / RPM20



NOTE: Model RPM10 does *not* support Room 2 Door Switch.

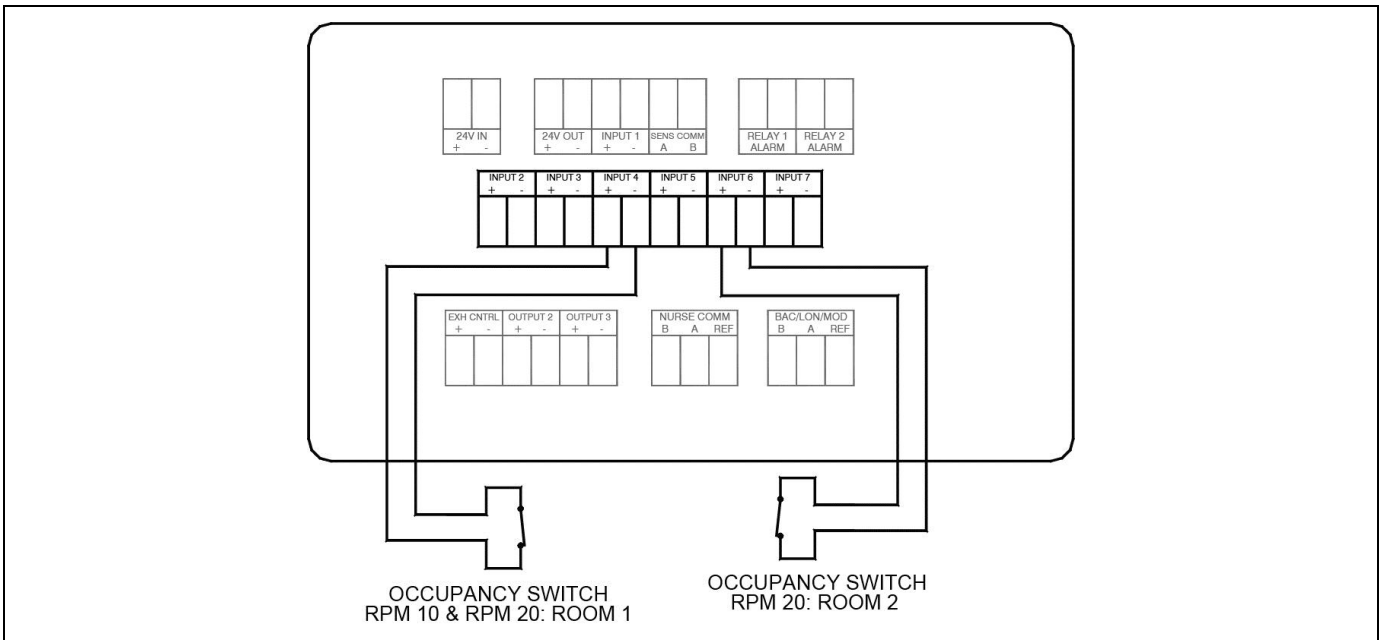

Figure 15. Optional Occupancy Sensor Wiring to Model RPM10 / RPM20



NOTE: Model RPM10 does *not* support Room 2 Occupancy Sensor.

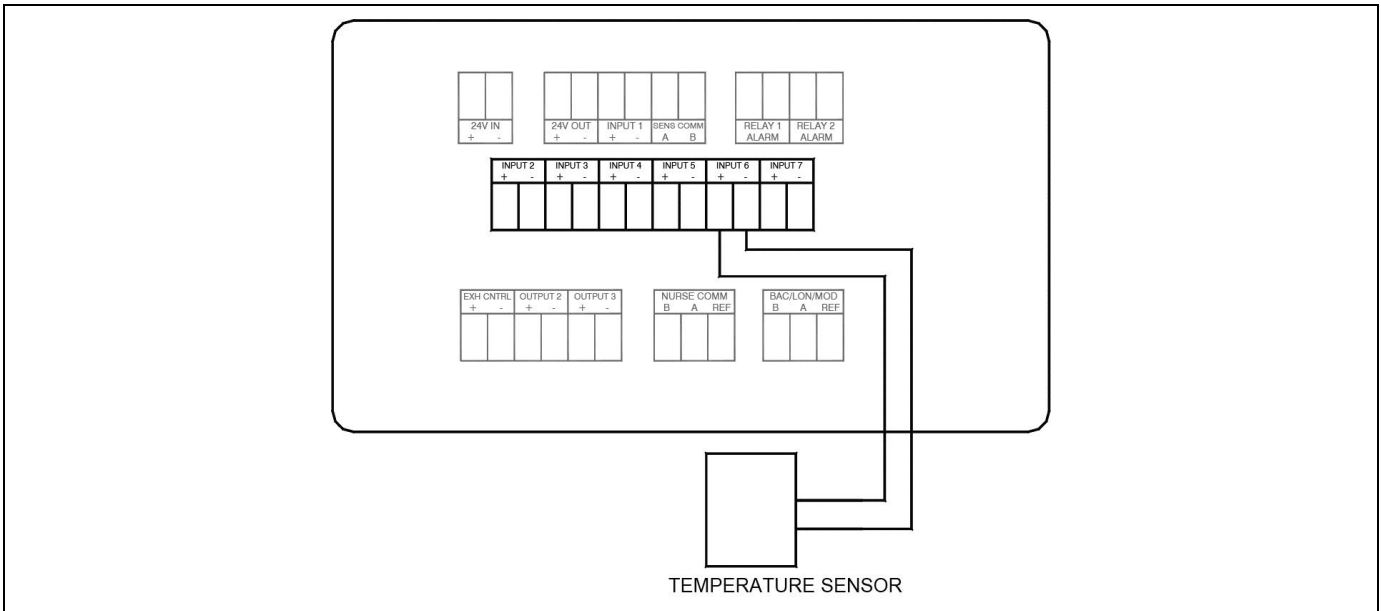

Figure 16. Optional Temperature Sensor Wiring to Model RPM20



NOTE: Model RPM10 does *not* support Temperature Sensor.

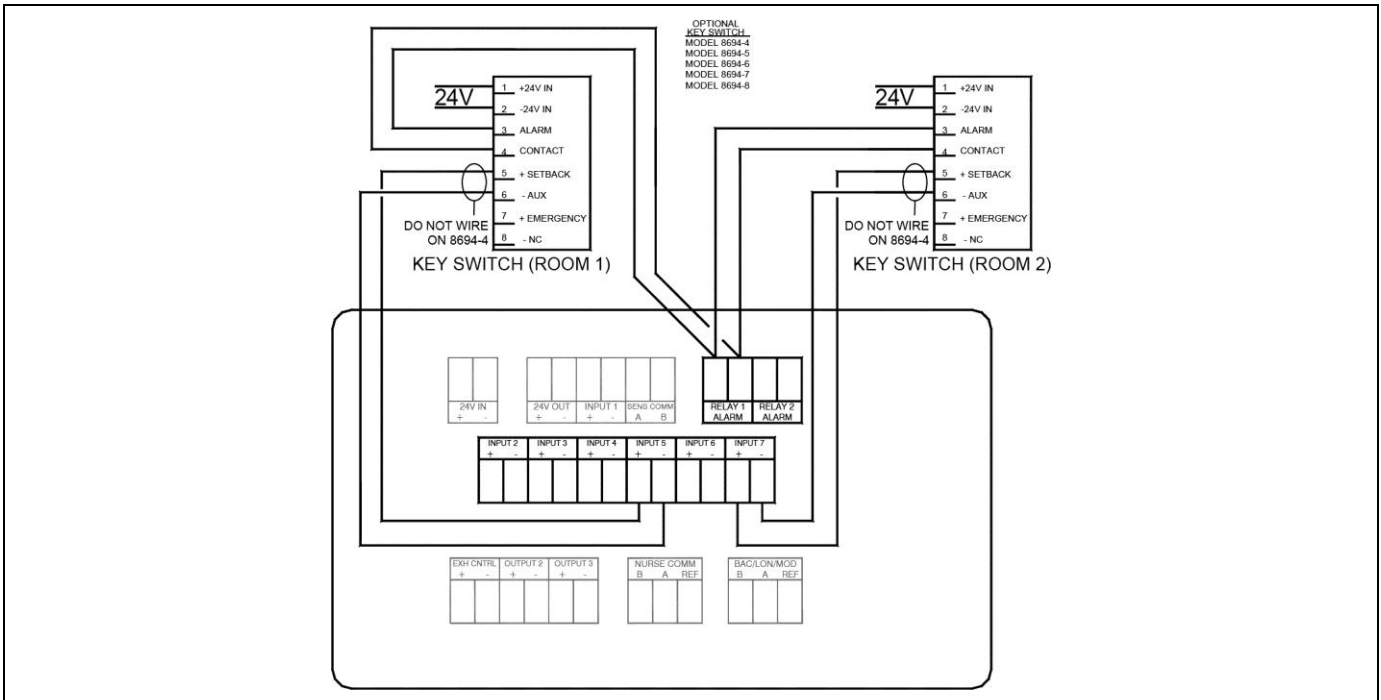

Figure 17. Optional Key Switch Wiring to Model RPM10 / RPM20



NOTE: Model RPM10 does *not* support Room 2 Key Switch.

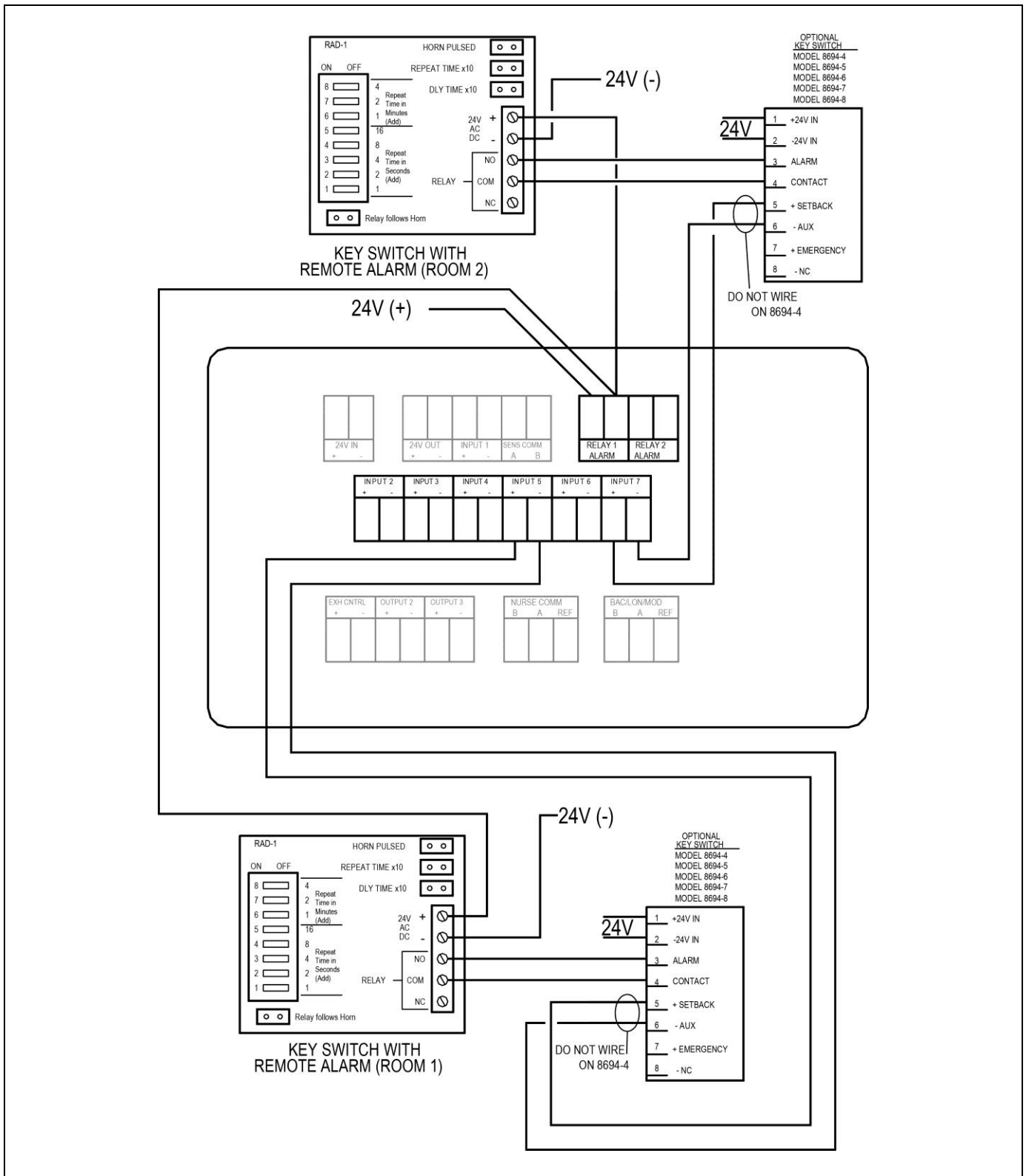

Figure 18. Optional Key Switch with Remote Alarm Wiring to Model RPM10 / RPM20



NOTE: Model RPM10 does *not* support Room 2 Key Switch with remote alarm.

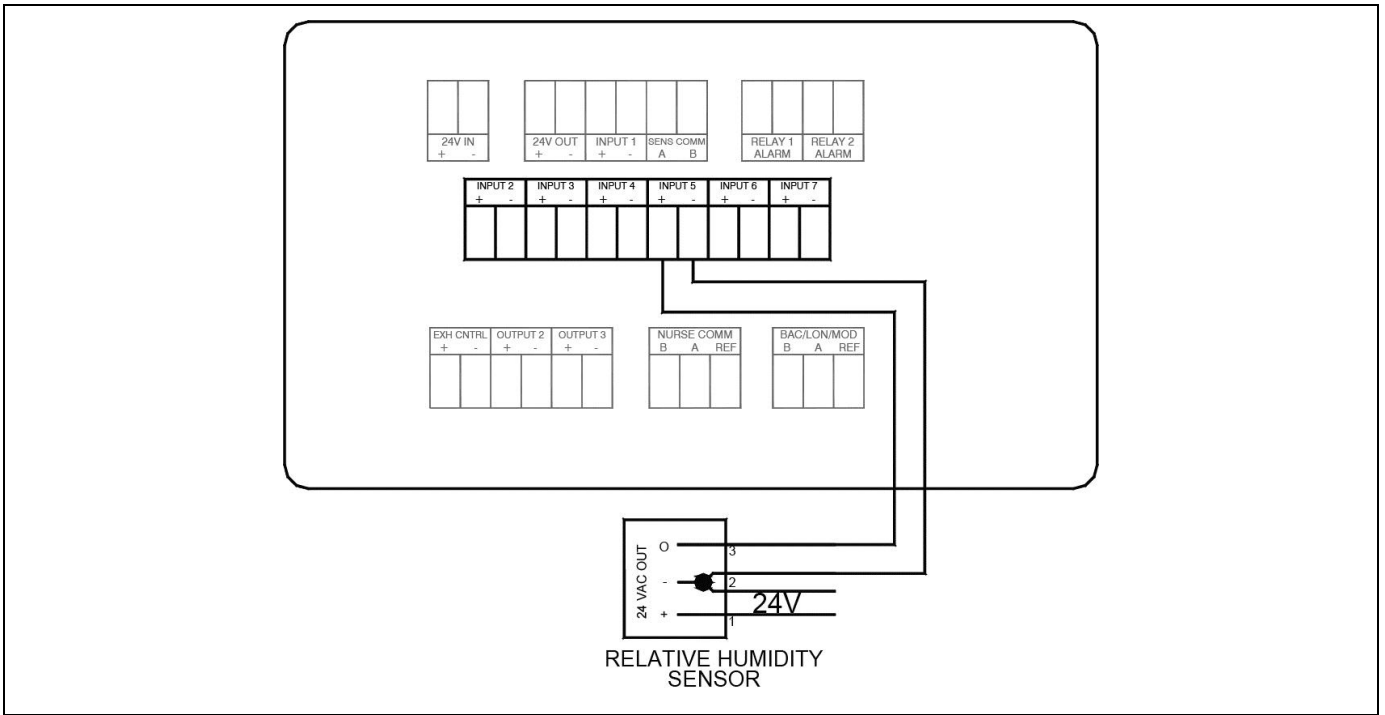

Figure 19. Optional Relative Humidity Sensor Wiring to Model RPM20



NOTE: Model RPM10 does *not* support Relative Humidity Sensor.

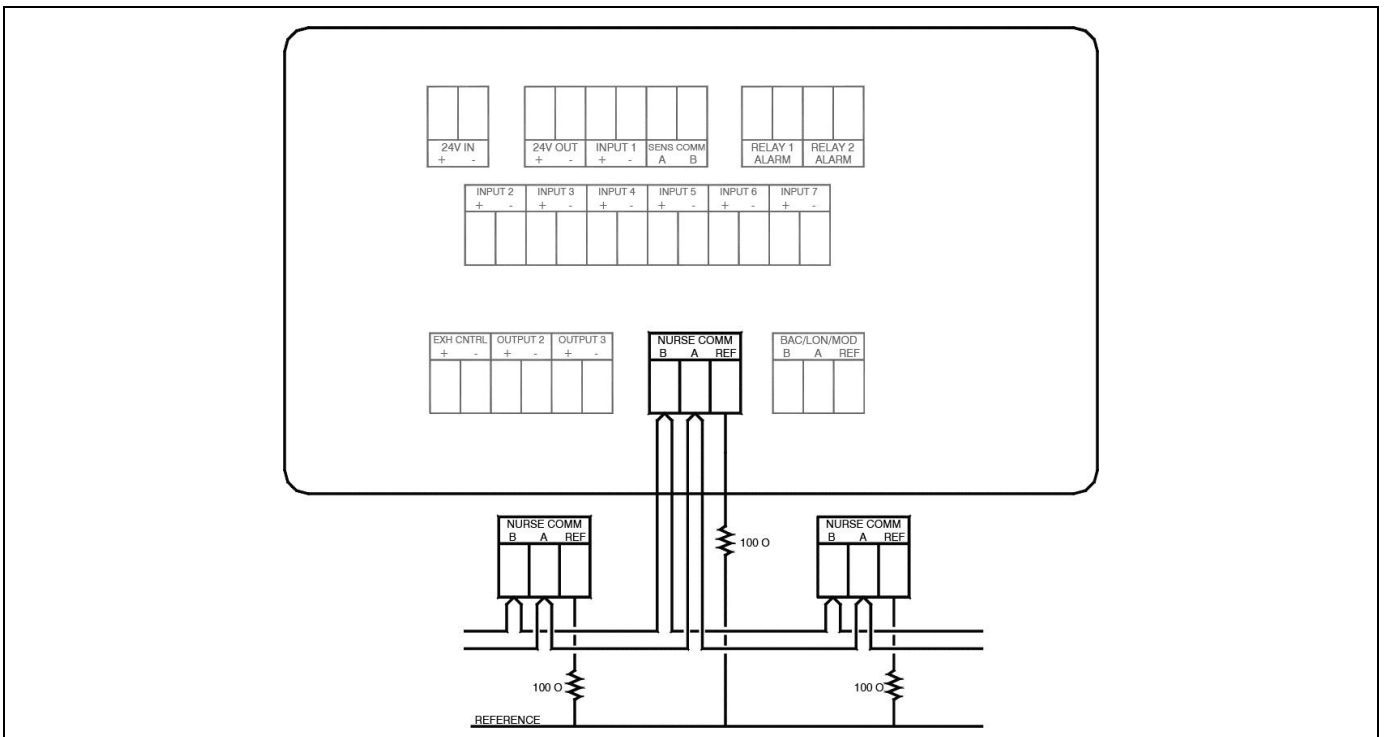

Figure 20. Optional Nurses Station Communications Wiring to Model RPM10 / RPM20

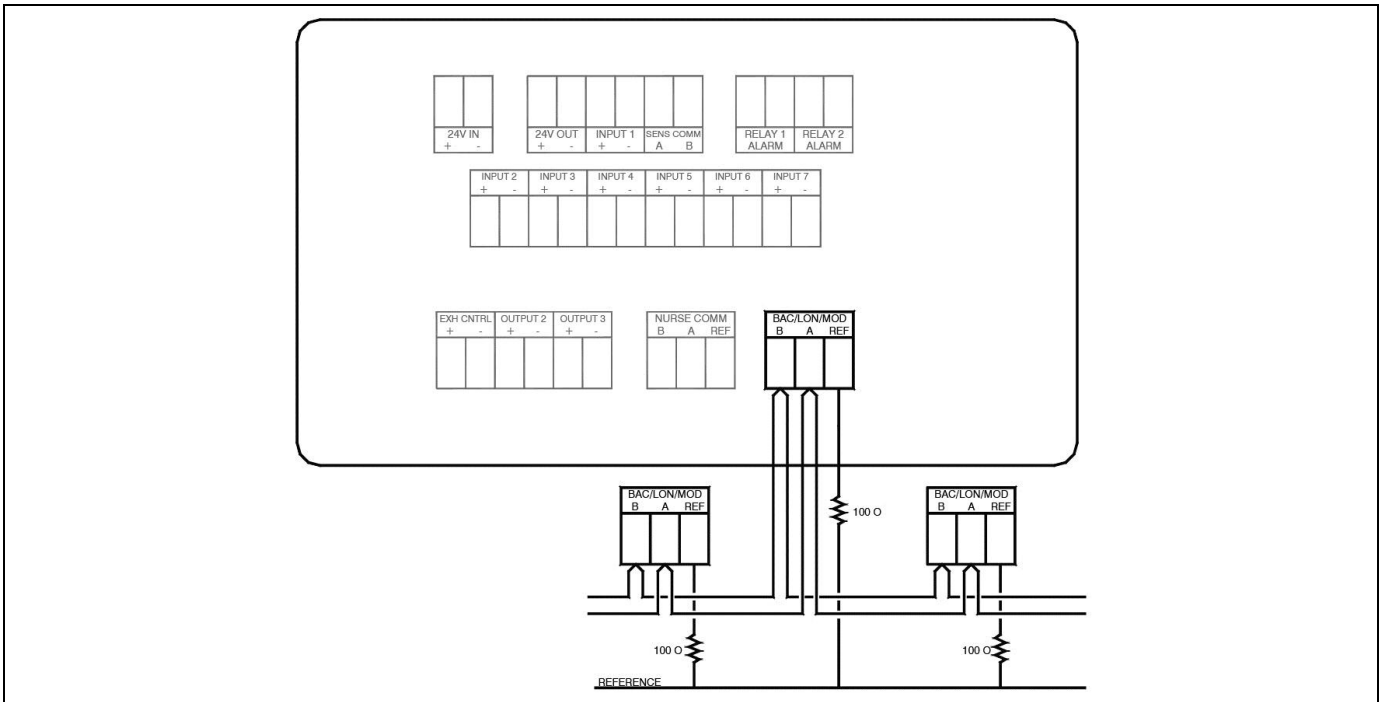

Figure 21. Optional Modbus and BACnet MS/TP Communications Wiring to Model RPM10 / RPM20

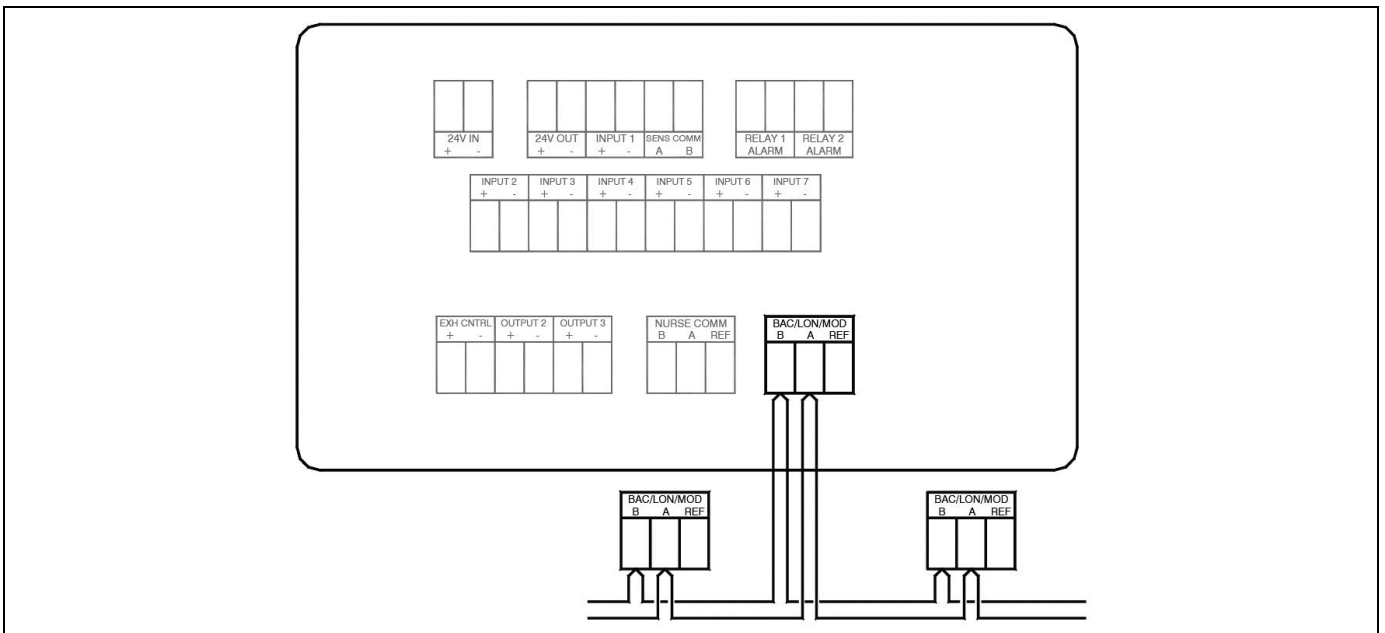

Figure 22. Optional LONworks Communications Wiring to Model RPM20-LON

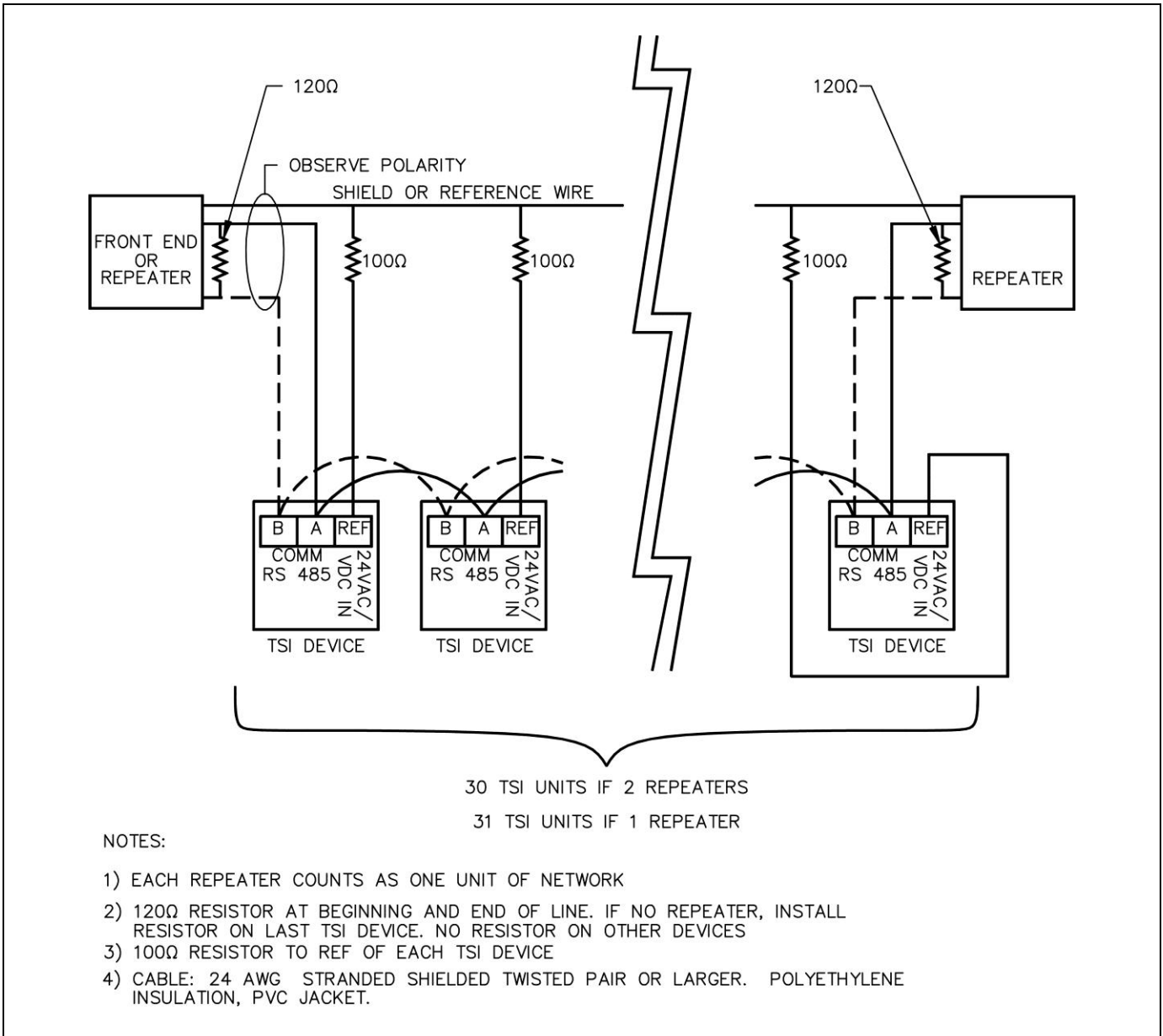

Figure 23. Proper Communication Wiring Diagram



UNDERSTANDING, ACCELERATED

TSI Incorporated – Visit our website www.tsi.com for more information.

USA	Tel: +1 800 874 2811	India	Tel: +91 80 67877200
UK	Tel: +44 149 4 459200	China	Tel: +86 10 8219 7688
France	Tel: +33 1 41 19 21 99	Singapore	Tel: +65 6595 6388
Germany	Tel: +49 241 523030		